

eman ta zabal zazu



Universidad
del País Vasco

Euskal Herriko
Unibertsitatea

LETREN
FAKULTATEA
FACULTAD
DE LETRAS

The Syntax of English and Basque wh-Exclamatives

English Syntax I

Zuriñe Zubiaguirre Sebastián

Universidad del País Vasco/Euskal Herriko Unibertsitatea, English Studies, 2016-2017

Tutor: Vidal Valmala Elguea

Department of English and German Philology and Translation and Interpretation

Area: English Philology

Index

1. Introduction.....	1
2. English wh-exclamatives.....	2
2.1. Description of English wh-exclamatives.....	2
2.2. The syntax of English wh-exclamatives.....	8
2.2.1. Zanuttini and Portner (2003).....	12
2.2.2. The Minimalist Approach.....	18
3. Basque wh-exclamatives.....	20
3.1. Description of Basque wh-exclamatives.....	20
3.2. The syntax of Basque wh-exclamatives.....	24
3.2.1. Basque wh-exclamatives as embedded constructions.....	30
4. Conclusions.....	31
References	

1. Introduction

Many scholars have attempted at analysing different clause types and trying to make explicit their syntactic structure. Exclamatives constitute one of the four syntactic clause types considered by Quirk et al. (1985) together with declaratives, imperatives and interrogatives. Exclamatives have the force of an exclamatory statement and they are used to express the speaker's affective stance (Collins, 2004). Exclamative clauses have received less attention compared to the rest of the clause types in the literature as a result of their lesser occurrence in everyday speech. Moreover, due to the exclamatory meanings and interpretations they give raise to, most previous work has been limited to their semantic and pragmatic analysis. Therefore, it is important to analyse the syntactic derivation of exclamative clauses. Some of the types of exclamative clauses considered in the literature are wh-exclamatives, verb-initial exclamatives and elliptical exclamatives among others, but there is no general agreement on the constructions that the term "exclamative" refers to. Nevertheless, the type which is widely considered to be exclamative is wh-exclamatives and these are the constructions which will be explored in the present paper. The following is an example of a wh-exclamative:

- (1) a. How beautiful his wife is! (Elliot, 1974: 233)

As (1) illustrates, a remarkable feature of wh-exclamatives is the presence of a wh-word, *what* or *how*, which appears in initial position of the sentence. Consequently, the resemblance of wh-interrogative constructions and wh-exclamative clauses has been commonly discussed. Exclamative clauses are also present in other languages and therefore it is a cross-linguistic phenomenon. The present paper will deal with wh-exclamative constructions in English and Basque, which are two languages typologically different. Basque is a head final language, as opposed to English, a head initial language. The aim of the present paper is to examine the syntax of wh-exclamatives and to analyse the approaches existing in the literature of wh-exclamatives in English and Basque in order to see their common grounds and dissimilarities. This paper is divided into five sections. The first section gives an overview of the basic descriptive facts of wh-exclamatives in English by focusing on their characteristic properties. The second section examines different approaches to the syntax of English wh-exclamatives that can be found in the literature. Additionally, in the third and fourth sections, the description of wh-exclamatives in Basque is presented as well as the few

approaches available to their syntax. In order to sum up the observations presented, some conclusions are drawn in the final section together with the limitations and problems found with the existing approaches.

2. English wh-exclamatives

All the scholars who have devoted their research to exclamatives have considered wh-exclamatives to be one of the constructions which belongs to this clause type, and therefore, these are the ones which will be presented in the following section.

2.1. Description of English wh-exclamatives

Wh-exclamatives are characterized by the presence of an exclamative phrase headed by *what*, seen in (2a) or *how* (2b), which appears in initial position of the sentence.

- (2) a. What a disaster it was!
b. How she hated it!

(Huddleston & Pullum, 2002: 918)

Many different constituents of the sentence can form the exclamative phrase and therefore, bear the exclamative force. In other words, wh-elements can fulfil different syntactic functions in exclamative constructions as shown in (3) (Quirk et al, 1985).

- (3) a. What ill-behaved children _ were on the tram today! [Subject]
b. What a provocative book she lent me _! [Direct Object]
c. How very kind you are _! [Predicative Subject]
d. How quickly they changed their minds _! [Adverbial]

(Trotta, 2000: 108)

These are the most commonly considered syntactic functions of the wh-phrase. However, Trotta (2000) includes the predicative object and indirect object functions to the syntactic functions fulfilled by wh-phrases, as the following examples show. Moreover, he considers the indirect object function of the wh-phrase to be marginal:

- (4) a. What terrible names they called him _! [Predicative Object]
b. (*?)What shallow people they awarded _ the prizes for best acting!
[Indirect Object]

(Trotta, 2000: 108)

In addition, the *wh*-phrase can also function as a complement of a preposition and the preposition can be either fronted or left stranded (Huddleston & Pullum, 2002; Collins, 2004). However, Quirk et al. (1985) indicate that the fronting of preposition as a *wh*-phrase occurs rarely:

- (5) a. With what unedifying haste he accepted the offer! [fronting preposition]
b. What unsavoury people he associates with! [stranding of preposition]
(Huddleston & Pullum, 2002: 918)

Wh-exclamatives can not only occur in matrix clauses, but they can also appear as embedded constructions. The major difference between matrix and embedded *wh*-exclamatives is that embedded *wh*-exclamatives allow the *wh*-phrases available in interrogatives to head the exclamative clause. These *wh*-phrases can be: *why*, *when*, *where* and *who* among others, as illustrated in (6). By contrast, matrix *wh*-exclamatives, as mentioned above, can only be headed by *what* and *how*.

- (6) a. {It is surprising...}
a. *who* I met.
b. *where* we spent the day.
c. *when* I began reading.
d. *why* she looked for me.

Another property of *wh*-exclamatives is that they constitute an unbounded dependency (Huddleston & Pullum, 2002). This means that *wh*-phrases of embedded clauses can also appear displaced in initial position of a matrix clause, as shown in the following example:

- (7) What a waste of time they thought [embedded clause it was likely to be]!
(Adapted from Huddleston & Pullum, 2002: 918).

Exclamatives *how* and *what* modify different types of constituents. Exclamative *how* can modify an adjective, as (8a) shows, a degree determinative such as *very*, *absolutely*, *remarkably*, as (8b) illustrates, a verb, as in (8c) or an adverb, as in (8d) (Huddleston & Pullum, 2002). Therefore, *how* can have the syntactic function of modifier and adjunct (Collins, 2004) and is a degree modifier. The modifier function of the *wh*-phrase is illustrated in (8a,b) and the adjunct function in (8c,d):

- (8) a. How tall they are!
b. How very much time we wasted!
c. How they deceived her!

- d. How quickly it grows!
(Huddleston & Pullum, 2002: 919)

Collins (2004) noticed that exclamative *what* functions as a modifier in a noun phrase. Huddleston and Pullum (2002) observe that exclamative *what* can be followed by a count noun, as shown in (9a), a plural noun (9b), or a mass noun, as (9c) illustrates. When followed by a count noun the exclamative is headed by *what a* (9a), and when followed by a mass or a plural noun it is *what* which heads the exclamative (9b-c). Furthermore, they also noticed that *what* exclamatives are concerned with quality and degree.

- (9) a. What a game it was!
b. What games he played!
c. What music he played!
(Huddleston & Pullum, 2002: 919)

Besides, it can be observed that these wh-phrases have to appear obligatorily displaced, since the construction becomes ungrammatical when the wh-phrase appears in situ:

- (10) a. *It was what a disaster!
b. *She hated it how!
(Adapted from Huddleston & Pullum, 2002: 918)

The occurrence of the wh-phrase in initial position and the impossibility of having it in situ, as shown in (10a-b), are properties which are also characteristic of wh-interrogatives. In fact, the similarities between wh-exclamatives and wh-interrogatives have been noted by many scholars such as Elliot (1974) and Huddleston and Pullum (2002) among others.

The most remarkable similarity is that both wh-exclamatives and wh-interrogatives contain a wh-phrase which obligatorily appears in the left-periphery of the sentence. However, in the case of wh-exclamatives, the wh-phrase can only be *what* or *how*, as (11a-b) show, whereas wh-interrogatives are compatible with a wider range of wh-phrases such as *when*, *why* or *where* which cannot appear in wh-exclamatives, as illustrated in (11c-d).

- (11) a. What games he played! (Huddleston & Pullum, 2002: 919)
b. How tall they are! (Huddleston & Pullum, 2002: 919)
c. *When you came!

d. *Where you went!

Another parallelism between wh-exclamatives and wh-interrogatives is that when the wh-element is a subject, both wh-interrogatives, as shown in (12b) and wh-exclamatives in (12a) lack subject-auxiliary inversion in matrix clauses (Trotta, 2000). Besides, both wh-exclamatives and wh-interrogative constructions lack subject-auxiliary inversion in embedded clauses, as illustrated by (13) (Trotta, 2000).

- (12) a. What an enormous crowd came! (Quirk et al., 1985: 833)
b. Who came to the party?

- (13) a. I asked whether she came to the party. [wh-interrogative]
b. I knew what a big house she had. [wh-exclamative]

Elliot (1974) noticed a number of differences between wh-exclamatives and wh-interrogatives that are listed below. Some elements such as *any*, *ever*, *whether* or *the hell* are allowed in wh-interrogatives but not in wh-exclamatives as illustrated in (14). On the contrary, certain adverbs such as *extremely*, *very* and *unbelievably* are possible in embedded wh-exclamatives (15a), as opposed to embedded wh-interrogatives (15b). Appositive clauses are also allowed in wh-exclamatives but not in wh-interrogatives, as the examples in (16) show. Finally, the exclamatory construction *what a* cannot be used in interrogatives (17).

- (14) a. How does Joe save any money?
b. *How Joe saves any money!
c. What did you ever do for me?
d. *What you ever did for me!
e. It's unknown whether Bill will be here (or not).
f. *It's incredible whether Bill will be here (or not).
g. I don't know where the hell he is.
h. *It's unbelievable where the hell he is.

(Elliott, 1974: 234-235)

- (15) a. It's amazing how $\left. \begin{array}{l} \text{very} \\ \text{unbelievably} \\ \text{extremely} \end{array} \right\}$ long he can stay under water.

- b. *I wonder how $\left. \begin{array}{l} \text{very} \\ \text{unbelievably} \\ \text{extremely} \end{array} \right\}$ long he can stay under water.

(Elliot, 1974: 234)

- (16) a. It's unbelievable who will be our next President, namely Zelda LaRue
b. *I don't know who will be our next President, namely Zelda LaRue.
(Elliot, 1974: 235)

- (17) a. *What a fast car does John drive?
b. *I wonder what a fast car John drives.
(Elliot, 1974: 235)

Wh-exclamatives have generally been considered to differ from wh-interrogatives in their lack of obligatory inversion. Scholars such as Elliot (1974) and Baker (1989) assume that the prototypical property of wh-exclamatives is that they do not involve (obligatory) subject-auxiliary inversion in matrix constructions (18c) as opposed to matrix wh-interrogatives (18a-b).

- (18) a. What did John buy?
b. *What John bought?
c. What a big house John bought!

Nevertheless, some scholars also consider that both matrix (19) and embedded wh-exclamatives (20) can have subject-auxiliary inversion as in wh-interrogatives (Elliot, 1974; Huddleston & Pullum, 2002; Quirk et al., 1985; Trotta, 2000). As shown above (18a-b), the crucial difference is that while this inversion in wh-exclamatives is optional, it is obligatory in wh-interrogatives.

- (19) a. *How often* have I bitterly regretted that day!
b. *What magnificent character* does she present in her latest novel!
(Quirk et al., 1985: 834)
- (20) a. The calmness and detachment of his tone suggested unawareness of how implicit was his own guilt in the words he had used to defend Cromwell. (The Brown University Corpus P07: 113 cited in Trotta, 2000: 110)
b. Two things are notable about such state laws: first, how intrusive they are, and, second, how vague is the language in which they are couched. (Bryson, 1995: 373 cited in Trotta, 2000: 110)

The use of inversion in exclamatives¹, in addition to being rarely used, occurs for literary purposes and has been considered to be archaic-sounding (Elliot, 1974; Huddleston & Pullum, 2002; Trotta, 2000). Moreover, due to the fact that both wh-

¹ Exclamatives can also contain the inversion of the subject and the auxiliary, forming a special type of exclamative known as verb-initial exclamatives or inverted exclamatives, as the following example illustrates: "Was he hungry!" (McCawley, 1988: 555).

interrogatives and wh-exclamatives involve a wh-phrase in initial position and when this wh-phrase is a subject there is no inversion, some wh-exclamatives can be ambiguous if they lack prosody and punctuation (Elliot, 1974; Huddleston & Pullum, 2002).

- (21) a. How much remains to be done!
 b. How much remains to be done?
 (Huddleston & Pullum, 2002: 918)

Hence, wh-exclamative sentences such as (21) are ambiguous between an exclamative reading “A remarkably large amount remains to be done” and an open interrogative reading “What is the amount that remains to be done?” (Huddleston & Pullum, 2002).

The similarities and differences between wh-exclamatives and wh-interrogatives are summarized in the following table:

	wh-exclamatives	wh-interrogatives
wh-phrase in initial position	OBLIGATORY	OBLIGATORY
wh-phrase in situ	IMPOSSIBLE	IMPOSSIBLE
<i>what, how, what a</i>	POSSIBLE	POSSIBLE except for <i>what a</i>
<i>when, who, why, where, whose</i>	IMPOSSIBLE	POSSIBLE
subject-auxiliary inversion in matrix clauses	POSSIBLE with literary flavour	OBLIGATORY
subject-auxiliary inversion in embedded clauses	POSSIBLE with literary flavour	IMPOSSIBLE
appositive clauses	POSSIBLE	IMPOSSIBLE

Trotta (2000) notices that wh-phrases can also appear followed by the complementizer *that* in wh-exclamative embedded constructions, as shown in (22):

- (22) a. And that brought it home to me. I thought *what a fabulous job* **that** they were doing and Mm. It got mm the old grey cells working... (*The Cobuild Direct Corpus* ukspok/04. Text: S9-604 cited in Trotta, 2000: 119)

- b.except in the Medical School I remember you saying *how lucky that* er the dean of medicine was. Now who was it? (*The Cobuild Direct Corpus* ukspok/04. Text: S832 cited in Trotta, 2000: 119)
- c. *What a mine of useless information that* I am! (Radford, 1988: 501 cited in Trotta, 2000: 119)

According to Zanuttini and Portner (2003), wh-exclamatives have certain semantic features which have an effect on their syntax as will be shown below. These properties are that they denote a set of alternative propositions and that they are factive. Factive predicates are those which presuppose the truth of their argument, and therefore, the argument clause needs to be true in order for the whole sentence to be true. Elliot (1974) was the first to note that wh-exclamative complements were limited to the complement position of factive predicates like *to know*, *to be aware*, *to realize* among others. As (23) shows, the exclamative complement *how very cute he is* is grammatical when embedded under factive verbs like *know* but ungrammatical under non-factive verbs like *think* or *wonder*.

- (23) Mary knows/*thinks/*wonders how very cute he is (Zanuttini & Portner, 2003: 46).

In addition, when embedded under these factive verbs in the present tense and with the first person as a subject, they cannot have the verb negated since they are contradictions, a negation of what the embedded complement presupposes (Elliot, 1974; Zanuttini & Portner, 2003), as the following examples shows:

- (24) *I don't know/realize how very cute he is (Zanuttini & Portner, 2003: 46).

2.2. The syntax of English wh-exclamatives

The approaches that will be presented below can be divided into two different types. Firstly, those which propose that the structure of wh-exclamatives is very similar to the one of wh-interrogatives such as Elliot's (1974), Grimshaw's (1979) or Radford's (2004) approach, and secondly, more complex structures such as Zanuttini and Portner's (2003) which propose a double layer CP for wh-exclamatives which is not present in wh-interrogatives.

In the early days of generative grammar, few studies analyzed the syntax of wh-exclamatives with two exceptions, Elliot (1974) and Grimshaw (1979). These scholars suggested a derivation for wh-exclamatives. Both of them noted that there was a

movement operation in the syntax of wh-exclamatives which was similar to the movement involved in wh-interrogatives. Elliot (1974) also proposed that the source of wh-exclamatives is *so* and *such* exclamatives (25a), so that the wh-phrases are originally in situ but they move to the left periphery of the sentence (25b).

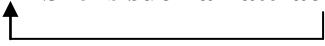
- (25) a. She is **such an attractive woman**!

 b. **What an attractive woman** she is!
 (Adapted from Elliot, 1974: 232)

We have seen that wh-exclamatives are not possible if the wh-phrase appears in situ (10). However, it remains unexplained what the derivation involved in wh-exclamatives is: does the wh-phrase move to that position or is it base-generated up there? Most scholars assume that there is movement, and if this assumption is correct, we should expect wh-exclamatives to have the same type of restrictions that apply in other constructions involving A' movement. In order to test this, and since it has not been done so far in the literature in a systematic way, in what follows I apply several tests to wh-exclamatives to see whether there is movement in wh-exclamatives. It is well known in the literature that adjuncts, subjects and complex NPs are islands for movement, and as a result, an element cannot be moved out of those domains. Example (26a) shows adjunct island effects in wh-interrogatives. If we apply the test to wh-exclamatives, we see the same island effect (26b) so the sentence is ungrammatical because *what beautiful dresses* cannot be extracted out of the relative clause and adjunct [*who wears*]. Wh-interrogatives are also affected by complex NP island effects, and as example (27a) shows, elements cannot be extracted out of complex NPs. In this case we can see again that wh-exclamatives are also sensitive to complex NP islands (27b-c). The same effects are found when extracting elements out of subjects in wh-interrogatives as example (28a) shows. When testing this subject island effect with wh-exclamatives, we can see that the same effect is found (28b-c).

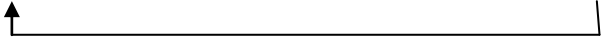
- (26) a. ***[What beautiful dresses]_i** does he like the girl [_{adjunct} who wears t_i]?

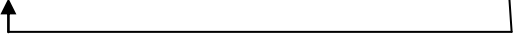







 b. ***[What beautiful dresses]_i** he likes the girl [_{adjunct} who wears t_i]!

 (27) a. ***What_i** did you [_{complex NP} make the claim that she is t_i]?

- b. ***[How pretty]_i** you [_{complex NP} made the claim that she is t_i]!
- c. ***[What a big house]_i** she [_{complex NP} believes the report that they have t_i]!
- (28) a. ***What_i** [_{subject} that she will buy t_i] is likely?
- b. ***[What a beautiful dress]_i** [_{subject} that she will buy t_i] is likely!
- c. ***[How fantastic]_i** is [_{subject} that John t_i] is known!
-

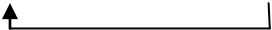
Furthermore, if there is movement in wh-exclamatives we expect to find traces which are left in the original position of the elements after the movement. Hence, we expect wh-exclamatives to allow parasitic gaps which are licensed by a coindexed trace of A' movement. This is found in the wh-interrogative (29a) in which we can have a gap due to the presence of a coindexed trace. By testing it with wh-exclamatives, we can see that the prediction is borne out, and therefore wh-exclamatives license parasitic gaps (29b-c). Wh-interrogatives are also affected by that-trace effects, according to which the complementizer *that* cannot be followed by a trace, as (30a) shows. However, the same construction becomes grammatical when there is no complementizer *that* (30b). As examples (30c,e) show, wh-exclamatives are also sensitive to that-trace effects, and the constructions become grammatical when the complementizer is not present (30d,f). Finally, a wh-phrase which is coindexed with a pronoun cannot cross over it in order to be placed in initial position, as the wh-interrogative in (31a) illustrates. Therefore, wh-interrogatives are affected by weak crossover effects. In fact, the same effects are found in wh-exclamatives as (31b-d) show, and as a result, the wh-phrase cannot cross over a pronoun which is coindexed with it.

- (29) a. **[What book]_i** did you file t_i without reading _{-i}?
- b. **[What an expensive book]_i** I filed t_i without reading _{-i}!
- c. **[What a delicious dish]_i** you cooked t_i despite not liking _{-i}!
- (30) a. ***[How much]_i** do you think that t_i remains to be done?
- b. **[How much]_i** do you think t_i remains to be done?
-

- c. ***[How much]**_i I think that t_i remains to be done!

- d. **[How much]**_i I think t_i remains to be done!

- e. ***[What a strange man]**_i you heard that t_i won the race!

- f. **[What a strange man]**_i you heard t_i won the race!

- (31) a. ***Who**_i does his_i mother love t_i ?

- b. ***[What good students]**_i their_i teacher punished t_i !

- c. ***[What a bad dog]**_i his_i owner hit t_i !

- d. ***[What a strange man]**_i his_i mother loves t_i !

Hence, we can conclude that these tests provide enough evidence to support a movement analysis of wh-exclamatives, as has been assumed in the literature. Once we know that there is movement in wh-exclamatives, we need to determine which position the wh-phrase moves to. So far, we have evidence to assume that the wh-phrase moves to a left-periphery position preceding the subject. Additionally, Trotta (2000) has noted that in those cases of optional subject-auxiliary inversion, as the examples (19) mentioned above show, the wh-word appears before the auxiliary (Trotta, 2000).

- (19) a. *How often* have I bitterly regretted that day!
 b. *What magnificent character* does she present in her latest novel!
 (Quirk et al., 1985: 834)

The evidence presented indicates that the wh-phrase appears at least in the specifier of the CP. This was Elliot's (1974) intuition when he said that the movement of wh-exclamatives was similar to the movement of wh-interrogatives, even if he did not use the word specifier CP to name this position, since a different notation was used at the time. Therefore, the wh-phrase constituent is located in a position which is above the position of the raised auxiliary, and therefore, it must be placed in a position higher than the head of the CP. Moreover, as was previously mentioned, wh-exclamative phrases can also appear preceding *that* complementizers, and therefore, this reinforces the evidence that the position of these wh-phrases must be preceding the head of the CP

position. Trotta (2000) proposes that the position of the wh-phrase in exclamatives is the same as the position of the fronted wh-phrase in interrogatives, as he calls, a pre-comp position, which in other words, is the specifier of the CP position.

Taking all the characteristics mentioned above into account, the following could be considered the syntactic representation of an English wh-exclamative:

(32)

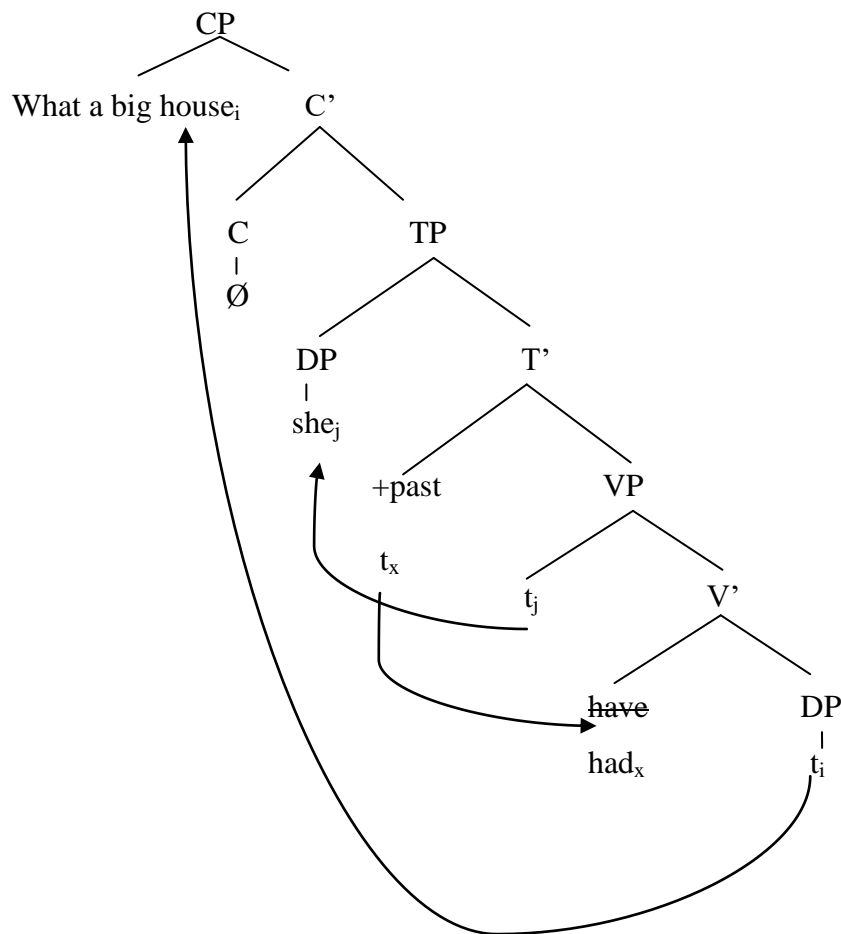

However, there are still several differences between wh-exclamatives and wh-interrogatives such as the factive property and the typical lack of inversion which are left unexplained by the equation of the wh-interrogative and wh-exclamative syntax. To the end of explaining these distinct properties, Zanuttini and Portner (2003) and Radford (2004) have recently elaborated approaches which will be explained below.

2.2.1. Zanuttini & Portner (2003)

Zanuttini and Portner (2003) propose that wh-exclamatives have two syntactic properties: factivity and denoting a set of alternative propositions. These properties

contribute to the semantic content of wh-exclamatives and characterize them. They suggest that wh-exclamatives contain a wh-operator-variable structure which makes the exclamative denote a set of alternative propositions and an abstract factive morpheme which serves to explain the incompatibility of exclamatives with non-factive predicates.

Firstly, they suggest that this abstract factive morpheme is located in a CP layer which is not present in wh-interrogatives. Therefore, they provide evidence to prove that the CP structure has more than one layer. This is also a way to prove that wh-interrogatives and wh-exclamatives are syntactically different. In order to show that there is a second layer of CP in wh-exclamatives, they analyze the different behaviour of wh-exclamatives and wh-interrogatives regarding their interaction with left dislocation. To this end, they show evidence coming from Paduan, since it is in this language where there is an overt difference in the structure of wh-interrogatives and wh-exclamatives (Benincá, 1996 cited in Zanuttini & Portner, 2003). In Paduan wh-interrogatives, the wh-phrase can follow but not precede left dislocated elements (33). This also indicates that the left-dislocated element occupies a position higher than the specifier of the CP since it precedes wh-phrases:

- (33) a. A to sorela, che libro vorissi-to regular-ghe? (Paduan)
to your sister which book want-S.CL give-her
‘To your sister, which book would you like to give as a gift?’
b. *Che libro, a to sorela, vorissi-to regular-ghe?
(Zanuttini & Portner, 2003: 60)

However, they show that this is not the case in wh-exclamatives, since wh-phrases in wh-exclamatives may precede the left-dislocated element, as the following example shows:

- (34) Che bel libro, a to sorela, chi I ghe ga regalà!
what nice book to your sister that S.CL her have given
‘What a nice book, to your sister, they gave her as a gift!’
(Zanuttini & Portner, 2003: 60)

The relative order of wh-constituents and left-dislocated elements is thus as follows:

- (35) Left dislocation – WH exclamative – Left dislocation – WH interrogative
(Zanuttini & Portner, 2003: 60)

In addition, they point out another difference between wh-interrogatives and wh-exclamatives in Paduan. Wh-exclamative phrases can co-occur with the complementizer *che* in wh-exclamatives (36a) but not in wh-interrogatives (36b):

- (36) a. Cossa *che* I magnava!
 what that S.CL ate
 ‘What things he ate!’
 b. *Cossa *che* I magnava?
 what that S.CL ate
 ‘What did he eat?’

(Zanuttini & Portner, 2003: 60)

Hence, they hypothesize that both wh-exclamatives and wh-interrogatives involve movement to a CP related position, but that wh-exclamatives involve movement to a higher position than that targeted by wh-phrases in questions. They claim that the wh-phrase occurs in a higher CP which they name CP₂ in the specifier of the CP₂ specifically. Therefore, the lower CP head is filled by complementizers such as *che* in Paduan. This is a way of explaining the presence of the complementizer *che* without the violation of the Doubly-filled-COMP filter. According to the Doubly-filled-COMP filter, a CP cannot have its head and specifier positions filled simultaneously, as (37) illustrates. Therefore, if wh-exclamatives only had one CP level, the presence of a complementizer such as *che* together with the wh-phrase in the specifier position would cause the violation of the doubly-filled-COMP filter. Hence, the double level of the CP in wh-exclamatives proposed by Zanuttini and Portner (2003) would avoid this violation. On the other hand, in the case of wh-interrogatives, the complementizer *che* is not possible since there would be a violation of the Doubly-filled-COMP filter, as there is only one CP layer in wh-interrogatives.

(37)

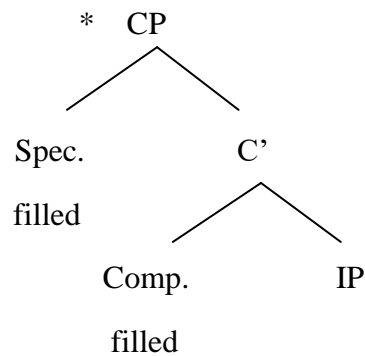

Moreover, Zanuttini and Portner (2003) reinforce the idea that there is an extra CP layer in wh-exclamatives by claiming that factivity is syntactically encoded in the lowest CP. This is based on the idea that factive complement clauses involve CP-recursion and that there is a factive operator in the lower CP layer, as claimed by Watanabe (1993) cited in Zanuttini and Portner (2003). Watanabe (1993) supports his proposal by observing that adjunct extraction is more difficult from factive clauses than from non-factive clauses and therefore, factive clauses are islands for movement of adjuncts:

- (38) a. Why_i do you know t_i that she left crying? Because I saw her.
b. *Why_i do you know that she left crying t_i? Because she was sad.
- (39) a. Why_i do you think t_i that she left crying? Because she is always crying.
b. Why_i do you think that she left crying t_i ? Because she had an argument with her boyfriend.

As example (38b) shows, it is not possible to extract an adjunct from a factive complement. On the other hand, adjunct extraction is possible from complements under non-factive predicates as the examples in (39) show. This phenomenon is explained by the presence of a factive operator in the lower specifier of the CP which blocks the movement of the adjunct (Watanabe, 1993). However, in the case of non-factive predicates such as the sentences in (39), there is no factive operator blocking the movement. Zanuttini and Portner (2003) adopt this proposal in order to prove that there is a factive operator in exclamatives and as a result, that a second level of the CP is needed in order to have a position for it.

Secondly, as mentioned above, Zanuttini and Portner (2003) also consider wh-exclamatives to have the property of denoting a set of alternative propositions.

Therefore, they argue that this property is syntactically represented as a wh-operator-variable structure in the specifier of CP₁. Watanabe (1993) adopts the proposal of Authier (1992), which is that a clause with any type of material in the specifier of its highest CP is typed as a wh-clause. Therefore, this serves to account for the fact that wh-exclamatives must have their higher CP filled so that they are typed as wh-clauses. Moreover, in order to explain the obligatoriness of the movement in wh-exclamatives, they claim that the specifier of the CP in the higher position must be always filled since the wh-phrase cannot appear in situ. According to them, this property is responsible for the similarities across languages of wh-exclamatives and wh-interrogatives due to the fact that both clause types denote sets of propositions.

Zanuttini and Portner (2003) apply these two proposals to wh-exclamatives and conclude that exclamatives must have two levels of the CP: the highest specifier in order for the exclamative to be typed as a wh-clause and the lowest specifier with the factive operator, as shown in the representation of (40b) for Paduan and (41b) for English.

- (40) a. *Che alto che I ze* (Paduan)
 what tall that S.CL is
 ‘How tall he is!’
 b. [_{CP} [*che alto*]_i [[_C Ø] [_{CP} **FACT** [_C *che*] I ze t_i]]]
-

(Adapted from Zanuttini & Portner, 2003: 64)

- (41) a. How tall he is!
 b. [_{CP} [*how tall*]_i [[_C Ø] [_{CP} **FACT** [_C Ø] he is t_i]]]]
-

However, in this case, contrary to Watanabe’s (1993) prediction of island effects in factive clauses, the exclamative wh-phrase *che alto* in (40) and *how tall* in (41) are able to move past the factive operator. Zanuttini and Portner (2003) explain this by suggesting that the factive operator has not got a wh-feature and therefore, it does not block wh-movement to the specifier of the highest CP. Therefore, island effects of the factive operator do not apply in the case of wh-exclamatives and this makes wh-exclamatives the only clause type compatible with the combination of factivity and wh-movement.

They propose that the syntactic representations of wh-interrogatives and wh-exclamatives are as in (42) and (43) respectively:

(42) Wh-interrogatives:

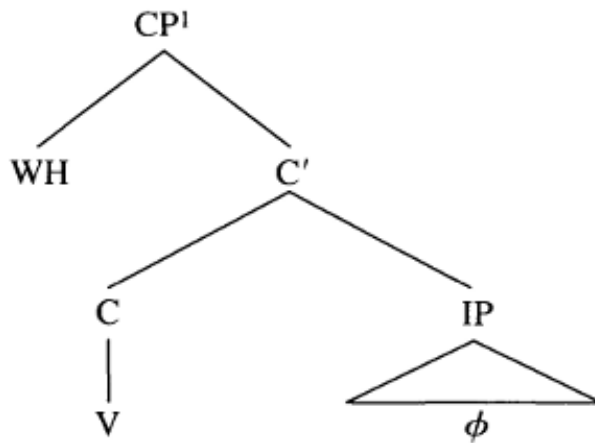

(Zanuttini & Portner, 2003: 61)

(43) Wh-exclamatives:

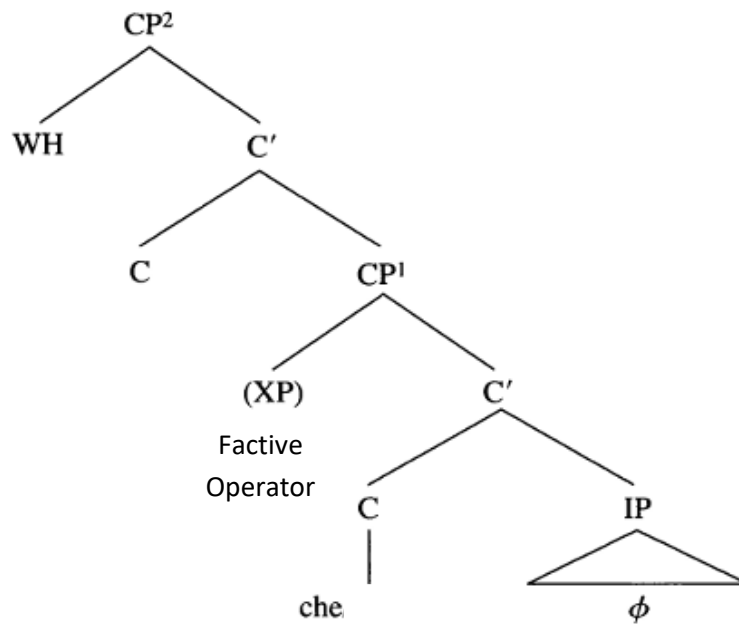

(Adapted from Zanuttini & Portner, 2003: 61)

Consequently, Zanuttini and Portner (2003) propose that the structure of wh-exclamatives in Paduan is similar to English wh-exclamatives. Although we find evidence in English to support that there is a CP containing a wh-phrase in the specifier position of wh-exclamatives, there is not much empirical evidence in English in favour of a double layer CP structure as there is in Paduan. Regarding the factive operator, even if Zanuttini and Portner (2003) indicate that the factive operator does not block the movement of elements due to its lack of a wh-feature, it could also be considered that this operator is not present in wh-exclamatives, and therefore, no empirical evidence of its presence is found in English wh-exclamatives.

2.2.2. The Minimalist Approach

The minimalist approach to wh-exclamatives explains the movement of the wh-phrase to the specifier of the CP and the lack of inversion of the auxiliary and the subject in the general case as opposed to wh-interrogative clauses. According to Radford (2004), wh-exclamative clauses are headed by a CP which has an exclamative head carrying [WH] and [EPP] features and exclamative force feature. It must be the case that there is a wh-feature since wh-exclamatives are headed by wh-phrases. The [WH] feature attracts the closest maximal projection with a wh-word, in the case of (45) *what fun*. The [EPP] feature stands for the Extended Projection Principle and it triggers the presence of a constituent in the specifier position, in this case of CP. Radford (2004) assumes that the wh-exclamative head does not have a tense feature, given that if there was one, it would trigger subject-auxiliary inversion, which is not triggered in the general case. Therefore, there is no inversion of the auxiliary and the subject since there is no [TNS] feature which would attract the auxiliary as happens in wh-interrogatives. Hence, *what fun* moves to the specifier of the CP and the [WH] and [EPP] features are deleted since they have been checked (Radford, 2004). Therefore, the initial structure without any movement would be as (44) illustrates, and the resulting structure is (45):

(44)

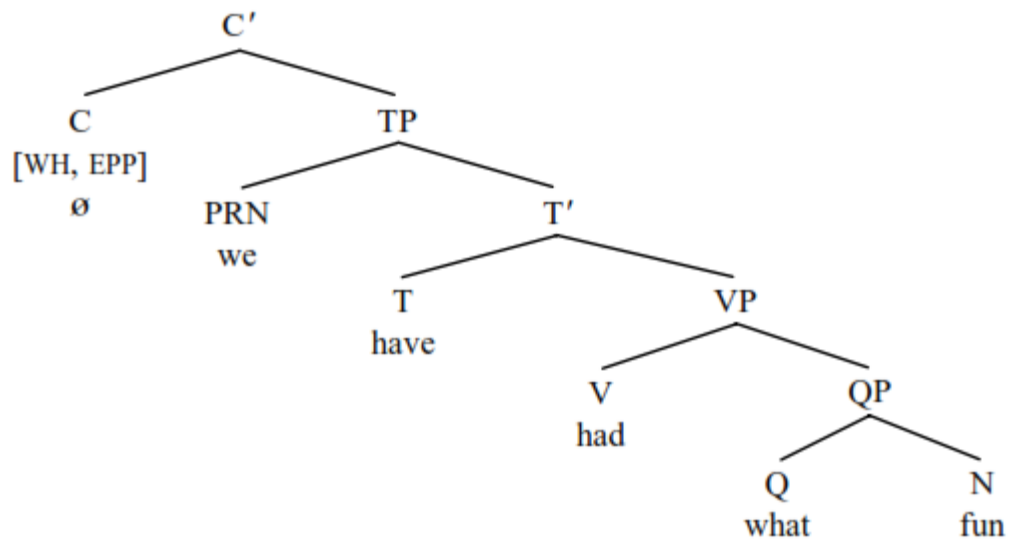

(Radford, 2004: 222)

(45)

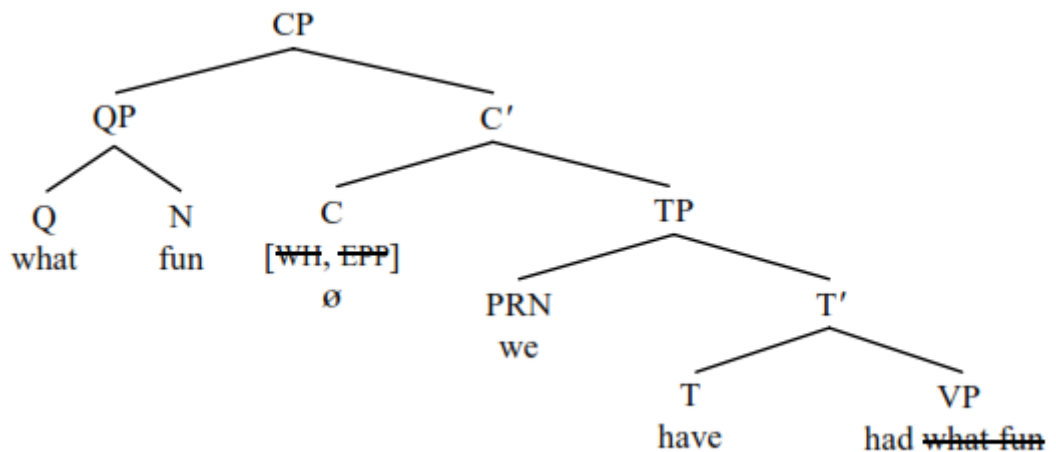

(Radford, 2004: 222)

Note that the wh-exclamative structure proposed by Radford (2004) is very similar to the one presented at the beginning of section 2.2, since it is a very similar structure to wh-interrogatives'. However, Radford (2004) is explicit regarding the feature that causes the lack of subject-auxiliary inversion generally in wh-exclamatives. In addition, the structure presented by Radford (2004) is less sophisticated than Zanuttini and Portner's (2003) but he tries to determine which the properties of the CP of a wh-exclamative are.

3. Basque wh-exclamatives

Basque and English differ, among other things, in that Basque is a head final language in many domains while English is a head initial language. As a result, the syntactic structures of these languages are expected to differ to a big extent.

3.1. Description of Basque wh-exclamatives

Basque wh-exclamatives have not received much attention in the literature, with the exception of Villasante (1979), Etxepare (2003) and more recently Artiagoitia (2005, 2006). Etxepare's (2003) analysis is purely descriptive and Villasante (1979) and Artiagoitia (2005, 2006) make explicit some proposals for the analysis of Basque exclamatives. In what follows, I will provide a summary of the descriptive study by Etxepare (2003).

Basque wh-exclamatives are characterized by the presence of a dislocated wh-phrase which appears in initial position. Moreover, the wh-phrase is followed by a finite verb, which is attached to a complementizer *-en*, as (46) illustrates. This complementizer *-en* which is not present in English wh-exclamatives, also appears in other Basque embedded constructions such as indirect questions, as shown in (47).

(46) Zelako txakurra ikusi dudan!
what a dog.DET see AUX.COMP
'What a dog I saw!'

(47) Anek non bizi nintzen galdetu zidan
ane.ERG where live AUX.COMP. ask AUX.
'Ane asked me where I lived'.

The wh-phrase in Basque can have several syntactic functions. The examples (48a-d) illustrate the same syntactic functions considered by Quirk et al. (1985) for English wh-phrases and I have included the functions observed by Trotta (2000) in examples (48e-f). It is noted that a difference is found between the acceptability of the indirect object function of the wh-phrase in Basque and in English, since it seems more acceptable in Basque than it is in English.

(48) a. Zelako urtea amaitu dena! [Subject]
what year end AUX.COMP.DET.
'What a year ended! (de Rijk 1972:134 cited in Artiagoitia 2006: 157)

- b. Zer dakizu zuk! [Direct Object] (Artiagoitia, 2006: 157)
 what know you
 ‘What you know!’
- c. Zelako ona zaren zu! [Predicative Subject]
 how good be.COMP you
 ‘How good you are!’
- d. Nola ari den jokutzen! [Adverbial] (Etxepare, 2003: 564)
 how progr. AUX.COMP playing
 ‘How he is playing!’
- e. Zelako izen itsusia deitu zioten! [Predicative Object]
 what name ugly call AUX.COMP
 ‘What an ugly name they called him!’
- f. Zelako pertsona arraroei eman zizkieten opariak! [Indirect Object]
 what people strange.to give AUX.COM presents.ERG
 ‘?What strange people they gave presents to!’.

There is a wide range of *wh*-phrases available to form exclamatives as opposed to the English exclamative *wh*-phrases *what* or *how*. The exclamative phrase can be *zein*, *nolako*, *zelako*, *zenbat*, *zer* or *nola*. Firstly, *zein* ‘which’ ‘what a’ or ‘how’ requires a modified noun, as (49a) illustrates. Secondly, *nolako* ‘how’ and *zenbat* ‘how many’ require an overt noun (49b-c). *Zelako* ‘how’ is used with adjectives (49d) and *zer* ‘what’ is used with nouns (49e). Finally, *nola* ‘how’ can be followed by the verb (49f).

- (49) a. Zein etxe ederra ikusi dudan!
 which house nice.DET see AUX.COMP
 ‘What a nice house I saw!’
- b. Nolako gereziak dituen gereziondo horrek!
 how.REL cherries has.COMP cherry.tree that.ERG
 ‘Such cherries in that cherry tree!’
- c. Zenbat jende etorri den!
 how.many people come AUX.COMP
 ‘What a lot of people have come!’
- d. Zelako polita zaren!
 how pretty are.COMP
 ‘How pretty you are!’
- e. Ze(r) itxura txarra daukan alaba gazteak!
 what presence bad.DET has.COMP daughter young. ERG
 ‘The younger daughter sure looks bad!’
- f. Nola ari den jokutzen!
 how be.engaged.in AUX.COMP play.NOM.LOC
 ‘The way he is playing!’

(Etxepare, 2003: 564-565)

These Basque exclamatives can also be constructed with demonstratives. The demonstrative expression is an implicit degree marker. Therefore, instead of a wh-phrase, these exclamatives are formed with a demonstrative followed by an auxiliary, as shown in (50-51):

(50) Orixe da gixon lerdena!
 that.INTS AUX man strong.DET
 ‘What a strong man!’ (Urruzuno, 1988: 90 cited in Etxepare, 2003: 567).

(51) Orrek dira gauza miragarriak ikusten
 those are thing miraculous.DET.PL see.IMPF
 doguzanak gaurko egunetan!
 AUX.COMP.DET.PL today.REL days.LOC
 ‘What miraculous things we see nowadays!
 (Kirikiño, 1986: 54 cited in Etxepare, 2003: 567).

Basque wh-exclamatives can also appear in embedded clauses, and both matrix and embedded wh-exclamatives have the same structure. They are constructed with a wh-word and the complementizer *-en*, which appears attached to the auxiliary.

(52) Arrituko zinake, ezeren indarrik gabe eta esku
 Surprise. FUT AUX.POT any.GEN force.PRTT without and hand
 batekin zer gauzak egiten dituen
 one.with what things do.IMPF AUX.COMP
 ‘You would be surprised the kind of things he does without force and with a single hand.’
 (Iraola, 1962: 90 cited in Etxepare, 2003:565)

(53) Pentsa ezazu zenbat jende hurbilduko zaigun
 think AUX how.many people approach.FUT AUX.COMP
 ‘Imagine how many people will come to us.’
 (Etxepare, 2003: 565).

In the case of (52) it can be seen that the embedded exclamative [*zer gauzak egiten dituen*] has the same structure as the matrix exclamative which would be *Zer gauzak egiten dituen!*. This also happens in English, since the embedded exclamative in (53) [*how many people will come to us*] and the corresponding matrix exclamative *How many people will come to us!* have the same structure.

Nevertheless, matrix wh-exclamatives and embedded wh-exclamatives differ in Basque in the wh-words that can occur in each case. The set of wh-words that can occur

in matrix wh-exclamatives is a subset of those that can occur in embedded wh-exclamatives (Artiagoitia, 2006). Therefore, Basque wh-phrases such as *who*, *when* and *where* are possible in embedded wh-exclamatives (55) but not in matrix wh-exclamatives (54).

- (54) a. ?Nor etorri den batzarrera!
 who come AUX.COMP meeting.to
 ‘*Who came to the meeting!’
 b. ?Non edaten duen gaurko gazte jendeak!
 where drink AUX.COMP today.of young people.ERG
 ‘*Where the young people of today drink!’
 c. ?Noiz heldu den postaria!
 when arrive AUX.COMP postman.DET
 *When the postman arrived!

(Artiagoitia, 2006: 158)

- (55) {Harrigarria da, ez da sinestekoa}...
 surprising AUX neg. AUX believable
 {It is surprising}
 a. nor etorri den batzarrera.
 who come AUX.COMP meeting.to
 ‘who came to the meeting’.
 b. non edaten duen gaurko gazte jendeak.
 where drink AUX.COMP today.of young people.ERG.
 ‘where the young people of today drink’.
 c. noiz heldu den postaria.
 when arrive AUX.COMP. postman.DET.
 ‘when the postman arrived’.

(Artiagoitia, 2006: 158)

Besides, as it happens in English wh-exclamatives, the wh-phrase has to appear obligatorily displaced in the left-periphery of the sentence, and the construction becomes ungrammatical when the wh-phrase appears in situ:

- (56) *Mirenek zelako etxe polita daukan!
 miren.ERG what.a house beautiful have.COMP .
 ‘*Miren has what a beautiful house!’.

Basque wh-exclamatives, as well as English wh-exclamatives, have the property of being factive (Artiagoitia, 2006) and therefore, the propositional content of the sentence is taken as being true. This results on the impossibility of embedding wh-exclamative sentences under non-factive verbs as illustrated in (57):

- (57) a. Anek badaki/ *uste du/ *galdetzen du zelako ergela
ane.ERG knows thinks asks AUX how innocent.DET
den Jon
is.COMP jon
‘Ane knows/ *thinks/ *wonders how innocent John is’.

As illustrated in the example, it is possible to embed Basque wh-exclamatives under the factive verb *to know*, while it is impossible to embed them under non-factive verbs such as *to wonder* or *to think*.

Overall, the descriptions of English and Basque wh-exclamatives are very similar since they have the same basic properties such as the initial wh-phrase, the impossibility of having it in situ, factivity or the possibility of having embedded constructions. Nonetheless, among other things, they differ in the presence of a complementizer *-en* in Basque wh-exclamatives, which will be pivotal in its syntactic representation.

3.2. *The syntax of Basque wh-exclamatives*

The syntax of Basque wh-exclamatives has not received much attention in the literature. However, scholars such as Villasante (1979) already made a proposal concerning the structure of Basque wh-exclamatives which more recently has been made explicit by Artiagoitia (2006). The present section will be devoted to a review of the approaches to the syntax of Basque wh-exclamatives found in the literature.

Like in the case of English wh-exclamatives, most scholars such as Artiagoitia (2006) have assumed that the syntax of Basque wh-exclamatives and Basque wh-interrogatives does not differ substantially. This assumption implies that there is wh-movement in wh-exclamatives, and that wh-phrases are not base generated in their surface position. As shown in the above example (56), Basque wh-exclamatives are ungrammatical when the wh-phrase appears in situ:

- (56) *Mirenek zelako etxe polita daukan!
miren.ERG what.a house beautiful have.COMP .
‘*Miren has what a beautiful house!’.

Hitherto there are two possibilities in the derivation of wh-exclamatives: the wh-phrase can be moved from its original position or it can be base generated in the left-peripheral position. In the case of Basque wh-exclamatives, Artiagoitia (2006) has

applied some tests systematically to show that there is movement in wh-exclamatives. He considers that wh-movement in both wh-exclamatives and wh-interrogatives is subject to the same island effects. For instance, wh-islands are embedded sentences which are introduced by a wh-word. Therefore, it is not possible to extract a phrase out of a wh-island, as example (58a) illustrates in embedded wh-interrogatives, and the same effects are found in embedded wh-exclamatives (58b,c).

- (58) a. ? Nork esan didazu [_{island} zein auto erosi duen]?
 who tell AUX which car buy AUX.COMP
 ‘*Who did you tell me what car bought?’
- b. ? Nork esan didazu [zelako auto ederra erosi duen]?
 who tell AUX what a car nice buy AUX.COMP
 ‘*Who did you tell me what a nice car bought?’
- c. ? Zein egunkari esan didazu [zenbat lagunek erosten duten]?
 which newspaper tell AUX. how many people buy AUX.COMP
 ‘*Which newspaper did you tell me how many people bought?’
- (Adapted from Artiagoitia, 2006: 162)

Nevertheless, this test does not provide evidence to show whether wh-exclamatives have the same island effects as wh-interrogatives, but they show that wh-exclamatives are islands for movement, so no element can be extracted out of wh-exclamatives. Artiagoitia (2006) also shows that Basque wh-exclamatives are sensitive to weak crossover effects as it happens with wh-interrogatives. According to the weak crossover phenomenon, a wh-word cannot cross over its coreferential pronoun. Example (59a) illustrates weak crossover effects in interrogatives: *nor* crosses over its coindexed pronoun in order to appear fronted and that violates the weak crossover condition. However, this sentence becomes grammatical when the pronoun is coindexed with the subject (59b). Artiagoitia (2006) shows that the same effect occurs in exclamatives, as examples (60-61) illustrate.

- (59) a. *Nor_i maite du [bere_i amak t_i] ?
 who love AUX his mother.ERG.
 ‘*Who_i does [his_i mother love t_i]?’
- b. Nork_i maite du t_i [bere_i ama]?
 who.ERG love AUX his mother.
 ‘Who_i loves his_i mother?’
- (Artiagoitia, 2006: 162)

(60) a. *Zelako txakur okerra_i jo duen bere_i jabeak t_i!
 what a dog bad hit AUX.COMP his owner
 ‘*What a bad dog_i his_i owner hit t_i!’

b. Zelako gizonak_i jo duen bere_i txakurra!
 what a man hit AUX.COMP his dog
 ‘What a man_i hit his_i dog!’

(Artiagoitia, 2006: 162)

(61) a. *Zenbat poema_i erre dituen bere_i autoreak!
 how many poems burn AUX.COMP his author.ERG
 ‘*How many poems_i his_i author burnt t_i!’

b. Zenbat autorek_i erre dituzten beren_i poemak!
 how many authors.ERG burn AUX.COMP their poems!
 ‘How many authors_i burnt their_i poems!’

(Artiagoitia, 2006: 162)

In order to show more evidence in favour of the movement in wh-exclamatives, I will apply some more tests. Like in English, Basque wh-interrogatives are sensitive to adjunct island effects (62a). In fact, if there is movement in wh-exclamatives, we also expect them to have adjunct island effects, and therefore, nothing should be able to move out of adjuncts in wh-exclamatives. This prediction is borne out as (62b) shows. The tests in (63a-b) serve to prove whether wh-interrogatives and wh-exclamatives are sensitive to subject island effects. As (63a) shows, Basque wh-interrogatives are affected by subject island effects, and if we apply the test to wh-exclamatives, we can see that nothing can be extracted out of subjects in wh-exclamatives (63b). Hence, wh-exclamatives are sensitive to both adjunct and subject island effects.

(62) a. *Zer_i etorriko da Ane t_i edan eta gero?
 ↑—————↓

what come AUX Ane drink and after
 ‘*What will come Ane after drinking?’

b. *[Zelako edari handia]_i etorriko da Ane t_i edan eta gero!
 ↑—————↓

what a drink big come AUX Ane drink and after
 ‘*What a big drink Ane will come after drinking!’

(63) a. Zer_i poztuko ninduke etxeko taldeak t_i irabazteak?
 ↑—————↓

what make.happy.FUT AUX house.OF team win.
 ‘*What would make me happy my home team won?’

- (66) a. Nolako liburua idatzi duzu?
 what book.DET write AUX
 ‘What book did you write?’
 b. *Nolako liburua zuk idatzi duzu?
 what book.DET you write AUX
 ‘*What book you did write?’
 c. Galdetu dute nolako liburua idatzi duzun
 ask AUX what book.DET write AUX.COMP
 ‘They have asked what book you have written’.
 d. *Galdetu dute nolako liburua zuk idatzi duzun.
 ask AUX what book.DET you write AUX.COMP
 ‘They have asked what book you have written’.
 (Artiagoitia, 2006: 162)

- (67) a. Nolako liburua idatzi duzun!
 what a book.DET write AUX.COMP
 ‘What a book you have written!’
 b. *Nolako liburua zuk idatzi duzun!
 what book.DET you write AUX.COMP
 ‘What a book you have written!’
 c. Harrigarria da nolako liburua idatzi duzun.
 surprising is what a book.DET write AUX.COMP
 ‘It is surprising what a book you have written.’
 d. *Harrigarria da nolako liburua zuk idatzi duzun.
 surprising is what a book.DET you write AUX.COMP
 ‘It is surprising what a book you have written.’
 (Artiagoitia, 2006: 162)

If we compare the structure of the sentences in English and Basque in examples (66d) and (67b,d), we can see that while English wh-phrases can be followed by the subject, this is not possible in Basque.

This shows that there is inversion between the subject and the verb in Basque wh-exclamatives. As a result, in order to know which the derivation of Basque wh-exclamatives is, we must find out whether the verb has suffered movement or it is the subject which has been displaced. To this end, and since the syntax of wh-exclamatives and wh-interrogatives is assumed to be similar, I will explain which the proposal of the derivation of Basque wh-interrogatives is. Ortiz de Urbina (1989) proposes that the wh-phrase in wh-interrogatives moves to the specifier of the CP position and that together with it, the verb is also moved to the head of the CP position. Artiagoitia (2000) adopts his proposal and gives account of how these movements occur. He explains the

movement of the wh-phrase by saying that the wh-phrase has a [+wh] feature which must be checked and therefore, that it needs to move to the specifier of the CP position. He suggests that there must be an abstract morpheme in the head of the complementizer which attracts the movement of the verb to the head of the complementizer position. Consequently, this is the proposal that I will assume for wh-exclamative wh-phrase and verb movement.

Taking all the information above into account, the following is the syntactic representation of wh-exclamatives:

(68)

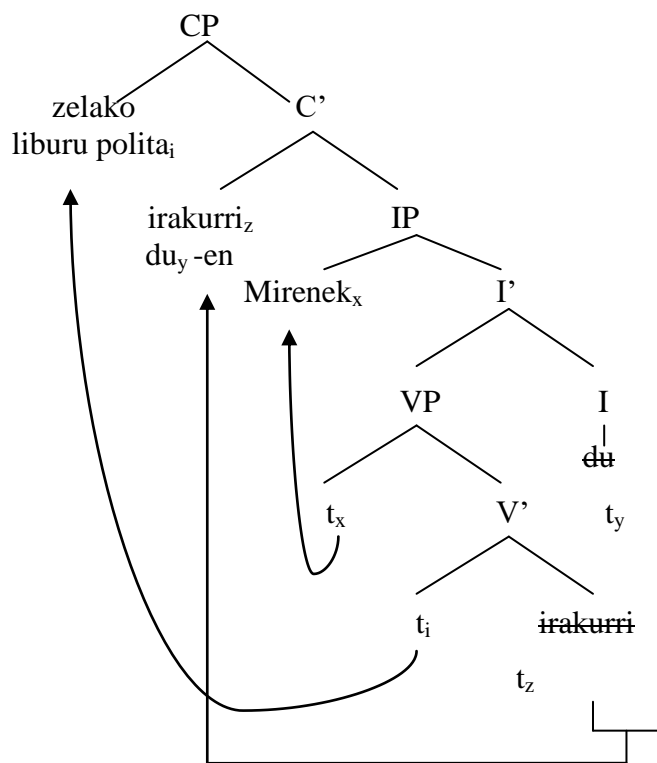

This syntactic representation does not show the factive operator or the double CP proposed by Zanuttini and Portner (2003) even if, as mentioned above, these Basque structures also have the property of being factive. Nonetheless, Artiagoitia (2006) considers the factivity of Basque exclamatives to be a result of the interpretation of exclamatives. Additionally, he states that there is no evidence to think that Basque exclamative syntax is as rich as the exclamative syntax proposed by Zanuttini and Portner (2003).

3.2.1. Basque wh-exclamatives as embedded constructions

Villasante (1979) was the first scholar to notice that Basque wh-exclamatives have the complementizer *-en*, which is typically a subordinating particle, attached to the inflected verb and proposed that wh-exclamatives are embedded constructions. This complementizer is also present in indirect questions in Basque, and therefore, Villasante (1979) considers this complementizer to be a subordination mark which is required by wh-exclamatives. According to him, wh-exclamatives are embedded under the main sentence which is omitted since it is presupposed by the hearer.

Following Villasante's claim, Artiagoitia (2006) proposes that matrix wh-exclamatives in Basque and in some other languages are embedded² under silent heads. He explains this by showing that in other languages such as English there is lack of subject-auxiliary inversion in wh-exclamatives (69a) as it happens in indirect questions (69b). As a result, not only has this approach been proposed for Basque, but it can also be applied to English.

- (69) a. How tall John is!
b. I know how tall John is

Nevertheless, this proposal leaves unexplained the already mentioned fact that certain wh-phrases which are possible in Basque embedded wh-exclamatives (55) are impossible in matrix wh-exclamatives (54), which also happens in English. Hence, if wh-exclamatives were embedded constructions, we would expect both matrix and embedded wh-exclamatives to be grammatical headed by the same wh-phrases.

- (54) a. ?Nor etorri den batzarrera!
 who come AUX.COMP meeting.to
 ‘*Who came to the meeting!’
b. ?Non edaten duen gaurko gazte jendeak!
 where drink AUX.COMP today.of young people.ERG
 ‘*Where the young people of today drink!’
c. ?Noiz heldu den postaria!
 when arrive AUX.COMP postman.DET
 *When the postman arrived!

(Artiagoitia, 2006: 158)

² Artiagoitia (2005) considers that wh-exclamatives do not have a separate semantic or syntactic structure, but that they are a subtype of wh-complements.

- (55) {Harrigarria da, ez da sinestekoa}...
 surprising AUX neg. AUX believable
 {It is surprising}
 d. nor etorri den batzarrera.
 who come AUX.COMP meeting.to
 ‘who came to the meeting’.
 e. non edaten duen gaurko gazte jendeak.
 where drink AUX.COMP today.of young people.ERG.
 ‘where the young people of today drink’.
 f. noiz heldu den postaria.
 when arrive AUX.COMP. postman.DET.
 ‘when the postman arrived’.
- (Artiagoitia, 2006: 158)

Additionally, it is noted that embedded wh-exclamatives in Basque can have the subject topicalized (70a), while matrix wh-exclamatives cannot (70b). Nonetheless, we do not find the same results in English, since topicalization is acceptable neither in embedded wh-exclamatives (71a) nor in matrix structures (71b) by native speakers.

- (70) a. Harrigarria da Mariak zelako etxe polita daukan.
 surprising AUX maria.ERG. what a house beautiful have.COMP.
 ‘*It is surprising Maria what a beautiful house has.
 b. *Mariak zelako etxe polita daukan!
 maria.ERG what a house beautiful have.COMP.
 ‘*Maria what a beautiful house has!’
- (71) a. *It is surprising Maria what a beautiful house has.
 b. *Maria what a beautiful house has!

Moreover, as it has been mentioned before, subject-auxiliary inversion is possible in English matrix wh-exclamatives for literary purposes, and this would also be unexpected if wh-exclamatives were embedded constructions. As a result, if wh-exclamatives were embedded under silent heads, the differences mentioned between matrix and embedded wh-exclamatives, would be left unexplained.

4. Conclusions

This paper has examined the syntax of English and Basque wh-exclamatives by focusing on the existing approaches in the literature. The approaches which support a similar syntactic derivation for wh-exclamatives and wh-interrogatives are successful in explaining the movement operation and the similarities of these constructions with wh-interrogatives. Nevertheless, wh-exclamatives also have properties which differ from

wh-interrogatives such as the factive operator or the lack of inversion in English which are left unexplained by these syntactic approaches. On the other hand, approaches like Zanuttini and Portner's (2003) propose a more complex structure for English wh-exclamatives than for wh-interrogatives. Even if there is evidence for a double layer CP in Paduan, no such an overt element has been found which can show the validity of this approach for neither English nor Basque wh-exclamatives. Additionally, it has been proposed that Basque wh-exclamatives could be embedded constructions under silent heads (Artiagoitia, 2005; Artiagoitia, 2006; Villasante, 1979). Although this approach is interesting since it explains the presence of the complementizer *-en* in Basque wh-exclamatives and the lack of subject-auxiliary inversion in English wh-exclamatives, it fails to take into account the fact that Basque and English embedded wh-exclamatives are compatible with a set of wh-phrases which cannot be used in matrix wh-exclamatives. It has also been observed that English wh-exclamatives can have inversion for literary purposes, hence if wh-exclamatives are embedded constructions, this behaviour would be unexpected. Moreover, it has been noted that topicalization is possible in Basque embedded wh-exclamatives but not in matrix ones, and therefore, this also remains unclear with the approach mentioned.

Moreover, although these languages are structurally dissimilar, some similarities have been pointed out. It has been shown that wh-exclamatives both in Basque and English involve movement or fronting of the wh-phrase to a left-peripheral position. Several tests have been carried out to see whether wh-exclamatives are sensible to movement effects and this has contributed to determining that in fact, there is movement of the wh-phrase in wh-exclamatives. Nonetheless, crucial differences have also been observed between wh-exclamatives in both languages such as the complementizer *-en* found in Basque and the fronting of the verb which English wh-exclamatives lack. These result on the different syntactic approaches proposed for these constructions. Overall, it could be concluded that the main difference between wh-exclamatives in Basque and English remains in their complementizer phrases due to the presence of an abstract morpheme and the complementizer *-en* which is found in Basque, as opposed to the simpler configuration found in the English CP as noted by Radford (2004).

This paper has thrown up many questions in need of further investigation. It remains to be seen whether the approaches presented can be used to derive the syntax of other

types of exclamatives, such as verb-initial exclamatives or elliptical exclamatives. Specifically, it would be interesting to analyse whether elliptical exclamatives such as “How great!” are derived by an ellipsis phenomena of the IP, or if they are just wh-phrases lacking the rest of the structure. Furthermore, this paper could provide insights to a cross-linguistic analysis of wh-exclamatives.

References

- Artiagoitia, X. (2000). *Hatsarreak eta Parametroak lantzen*. Vitoria-Gasteiz: Arabako Foru Aldundia.
- Artiagoitia, X. (2005). Remarks on the non-grammar of exclamatory complements. Manuscript from the UPV/EHU.
- Artiagoitia, X. (2006). Heiagora perpausak: euren egituraz eta hautapenez. In Fernandez, B. & Laka, I. (Eds.), *Andolin gogoan. Essays in honor of Professor Eguzkitza* (pp. 155-178). Bilbao: UPV/EHU.
- Authier, J.M. (1992). Iterated CPs and Embedded Topicalization. *Linguistic Inquiry*, 23(2), 329-336. Retrieved from <http://www.jstor.org/stable/4178771>.
- Baker, C.L. (1989). *English Syntax*. Cambridge: MIT Press.
- Benincá, P. (1996). La struttura della frase esclamativa alla luce del dialetto padovano. Italiano e dialetti nel tempo. In Benincá, P., Cinque, G., de Mauro, T., Vincent, N. (Eds.), *Saggi di grammaritca per Giulio C. Lepschy* (pp. 23-43). Rome: Bulzoni.
- Bryson, B. (1995). *Made in America*. London: Minerva.
- Collins, P. (2004). Exclamative Clauses: a Corpus-based Account. [Electronic version]. *Proceedings Word*, 56 (1), 1-17. doi: 10.1080/00437956.2005.11432550.
- Elliott, E. D. (1974). Toward a Grammar of Exclamations. *Foundations of Language*, 11(2), 231-246. Retrieved from <http://www.jstor.org/stable/25000769>.
- Etxepare, R., (2003). Exclamatives in Basque. In Hualde, J. I. & J. Ortiz de Urbina, J. (Eds). *A Grammar of Basque* (pp. 564-571). Berlin: Mouton de Gruyter.
- Francis, N., W., & Kucera, H. (1964). *The Brown University Corpus*. Retrieved from <http://clu.uni.no/icame/brown/bcm.html>.
- Grimshaw, J. (1979). Complement selection and the lexicon. *Linguistic Inquiry* 2, 279-326.
- Huddleston, R. & Pullum, G. (2002). *The Cambridge Grammar of the English Language*. Cambridge: Cambridge University Press.
- Iraola, V. (1962). *Oroitzak: eta beste ipui asko*. Donostia-San Sebastian: Auspoa Argitaletxea.
- Kirikiño (1986). *Abarrak*. Donostia: Euskal Editoreen Elkarte.
- McCawley, J. D. (1988). *The Syntactic Phenomena of English*. Chicago: University of Chicago Press.
- Ortiz de Urbina, J. (1989). *Parameters in the Grammar of Basque*. Dordrecht: Foris.
- Quirk, R., Greenbaum, S., Leech & Svartvik, J. (1985). *A Comprehensive Grammar of the English Language*. London: Longman.
- Radford, A. (1988). *Transformational Grammar: A First Course*. Cambridge: CUP.
- Radford, A. (2004). *Minimalist Syntax*. Cambridge: Cambridge University Press.
- Rijk, R. de (1972). *Studies in Basque Syntax : Relative Clauses*. MIT doctoral thesis. In Rijk, R. de (1997). *De lingua vasconum: selected writings* (pp. 71-149). Donostia: ASJU supplement.
- Sinclair, J. (1987). *The Cobuild Direct Corpus*. Retrieved from <http://web.quick.cz/jaedth/Introduction%20to%20CCS.htm>.
- Trotta, J. (2000). *Wh-Clauses in English: Aspects of Theory and Description*. Amsterdam: Rodopi.
- Urruzuno, P. M. (1988). *Ipuinak*. Leioa: EHU.
- Villasante, L. (1979). *Sintaxis de la oración compuesta*. Oñati: Editorial Franciscana de Aránzazu.

- Watanabe, A. (1993). Larsonian CP recursion, factive complements, and selection. In Amy J. Schafer, (Ed.), *Proceedings of the North Eastern Linguistic Society XXIII* (pp. 523-537). Amherst MA: GLSA.
- Zanuttini, R., & Portner, P. (2003). Exclamative clauses: At the syntax-semantics interface. *Language*, 79(1), 39–81. doi:10.1353/lan.2003.0105.